

Ideal for Tempering Forced Air in Many Industrial Processes

There are numerous applications of air duct heaters at industrial and commercial sites. Whether it is an open coil air duct heater, a tubular or a finned tubular duct heater, each duct heater serves the main purpose which remains the same.

However, the type may vary based on their construction, working, advantages, disadvantages, and functionality differences.

Air duct heaters can be designed specifically for high pressure and/or hazardous locations. Turnkey systems including the duct heater, power and temperature control panel, and the temperature and over-temperature sensors can also be provided.

Applications

One of the leading uses of tubular duct heaters is to process air in industrial heating applications and to temper forced air in a number of industrial processes. The heater can come in a number of different wattages. This will largely depend on the outlet of air temperature and the velocity of the air coming through inside the duct heaters.

The tubular heating elements that are used in duct heaters are important in a number of ways, primarily in terms of its strength. These heating elements are toughened up and designed to provide protection against corrosive air environments and even provide effective resistance to vibration in comparison to other heating elements of duct heaters such as open coil ones.

- Air Drying/ Curing Operations
- Annealing
- Autoclaves
- Booster Air Heaters
- Forced Air Comfort Heating
- Dehumidification
- Heat Treating
- HVAC



Fig 1. 120kW Casette Type Tubular Duct Heater

Performance Capabilities

- Watt Densities up to 40W/in² (6.2W/cm²)
- Recommended process temperatures from (-29°C to 650°C)
- Voltages up to 600VAC

Key Features

- Single and Three-Phase Voltages
- Stainless Steel Supports
- Field Replaceable Heating Elements, if required
- 2" - 3 1/2" Thick Insulation, if required
- General Purpose Terminal Enclosure
- Special Sizes, Wattages, and Materials Available Upon Request
- Built Stainless Steel Frame Available Upon Request

VEMA Process Air Duct Heaters are designed and manufactured according to customer specifications. Reliability and robustness are key drivers for our engineers.

Choosing A Duct Heater

A broad range of custom built electric duct heaters with capacities up to 1000kW is available upon request. It can be used for applications with the following voltages:

- 200V - 1 Phase or 3 Phases
- 600V - 1 Phase or 3 Phases
- 208V/ 240V - 1 Phase
- 208V - 3 Phases
- 415V - 3 Phases
- Other Voltages Available Upon Request

The English and metric graphs, shown on the following pages will help you to select the correct duct heater. These graphs include: Watt Density vs. Air Temperature/ Velocity, Watt Density vs. Sheath Temperature and Pressure Drop vs. Air Velocity.

These graphs, with the quick formulas on this page, along with information specific to your application, will determine the correct duct heater specifications. However, if engineering assistance is needed, contact your sales representative.

Required Application Information

- Desired outlet air temperature
- Inlet air temperature
- Delta T - the temperature difference between inlet and desired outlet temperature
- Air volume (CFM/CMM) measured at both inlet temperature and pressure
- Air velocity in feet per minute (FPM); meters per minute (MPM) which equals:

English	
FPM =	$\frac{\text{CFM measured at standard conditions}}{\text{Duct cross section area at heater in ft}^2}$
Metric	
MPM =	$\frac{\text{CMM measured at normal conditions}}{\text{Duct cross section area at heater in m}^2}$

Minimum duct heater wattage (kW). This can be determined by:

English	
kW =	$\frac{\text{CFM} \times \text{Delta T } (^\circ\text{F}) \times 1.1 \text{ (safety factor)}}{3000}$
Metric	
kW =	$\frac{\text{CMM} \times \text{Delta T } (^\circ\text{C}) \times 1.1 \text{ (safety factor)}}{48}$

NOTE: The duct heater, or combination of duct heaters, used for the process should be equal to or exceed the minimum wattage calculation.

Finned Tubular Elements vs Unfinned Tubular Elements

Finned Tubular Elements	Unfinned Tubular Elements
The most common design	Cost effective yet reliable design
Include the highest wattage / cross sectional duct area	Lower watt density, which requires more heating elements
Energy Saver	Protect from electrical shock
Made of stainless steel 304/316L/Incoloy 800 tube with corrugated fin wrapped around it	Made of stainless steel 304/316L/Incoloy 800 tube
Maximize the heat transfer surface of the element	Can be installed close to a register or grille
Provide lower operating temperature	Slower heat dissipation rate
Designed for low maintenance	Designed for low maintenance

Fig 2. Type of Heaters Comparison

Checklist - Choosing The Proper Duct Heater (cont.)
 Element Watt Density vs. Sheath Temperature & Air Velocity

Use graph (English or Metric) to plot

- **Watt Density vs. Air Velocity** to determine **Sheath Temperature**
- or
- **Watt Density vs. Sheath Temperature** to determine the required **Air Velocity**

English

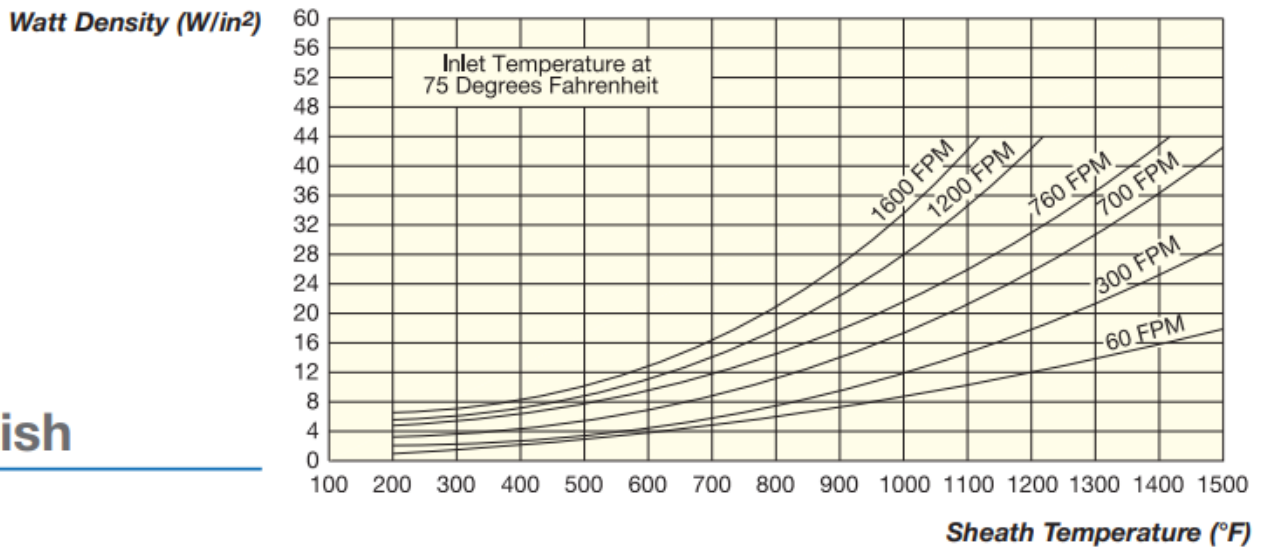

Metric

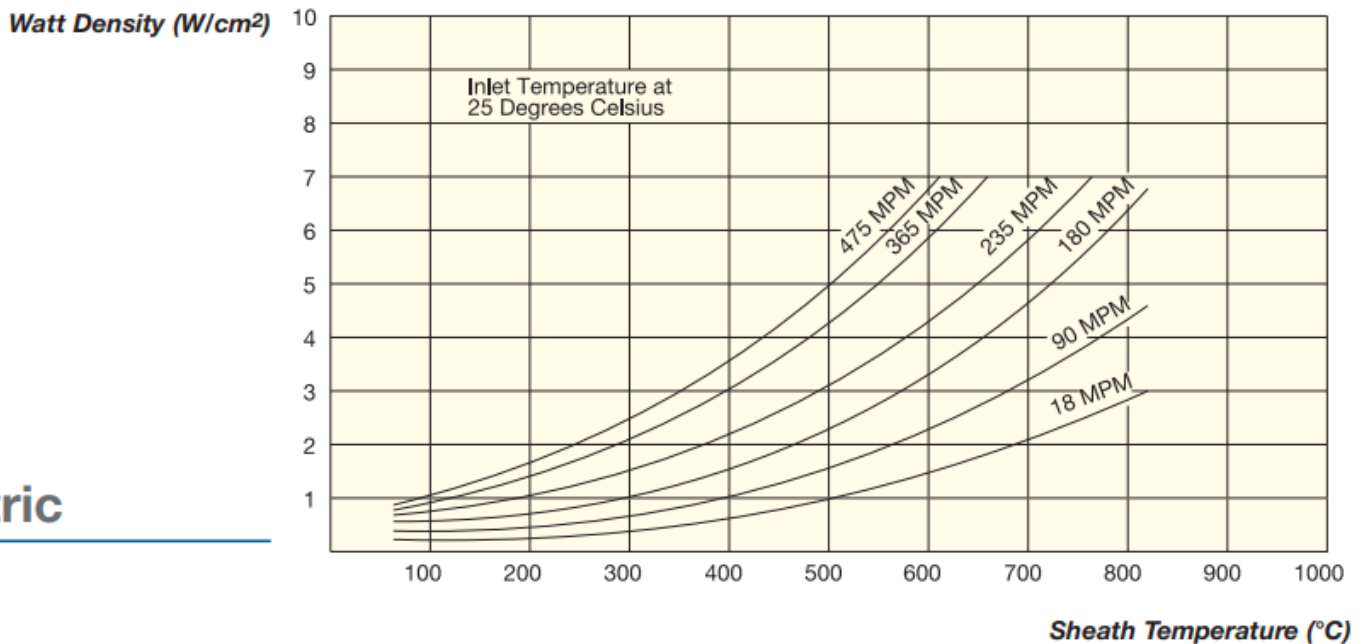
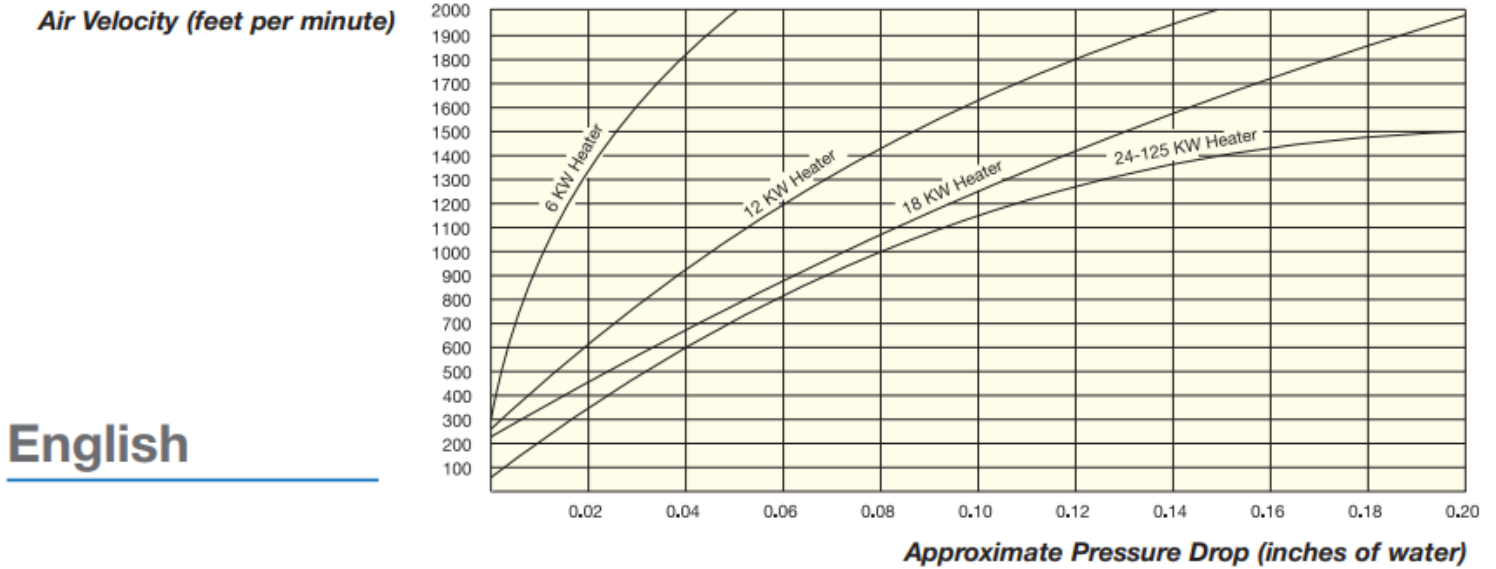

Fig 3. Watt Density vs. Sheath Temperature

Checklist - Choosing The Proper Duct Heater (cont.)
 Pressure Drop vs. Air Velocity

Use graph (English or Metric) to plot

- **Pressure Drop vs. Air Velocity** for standard duct heaters sizes used to properly **Size Blowers**



Calculating Air Velocity

$$\text{Velocity (feet/minute)} = \frac{\text{SCFM (CFM measured at standard conditions)}}{\text{Duct cross sectional area at heater in square feet}}$$

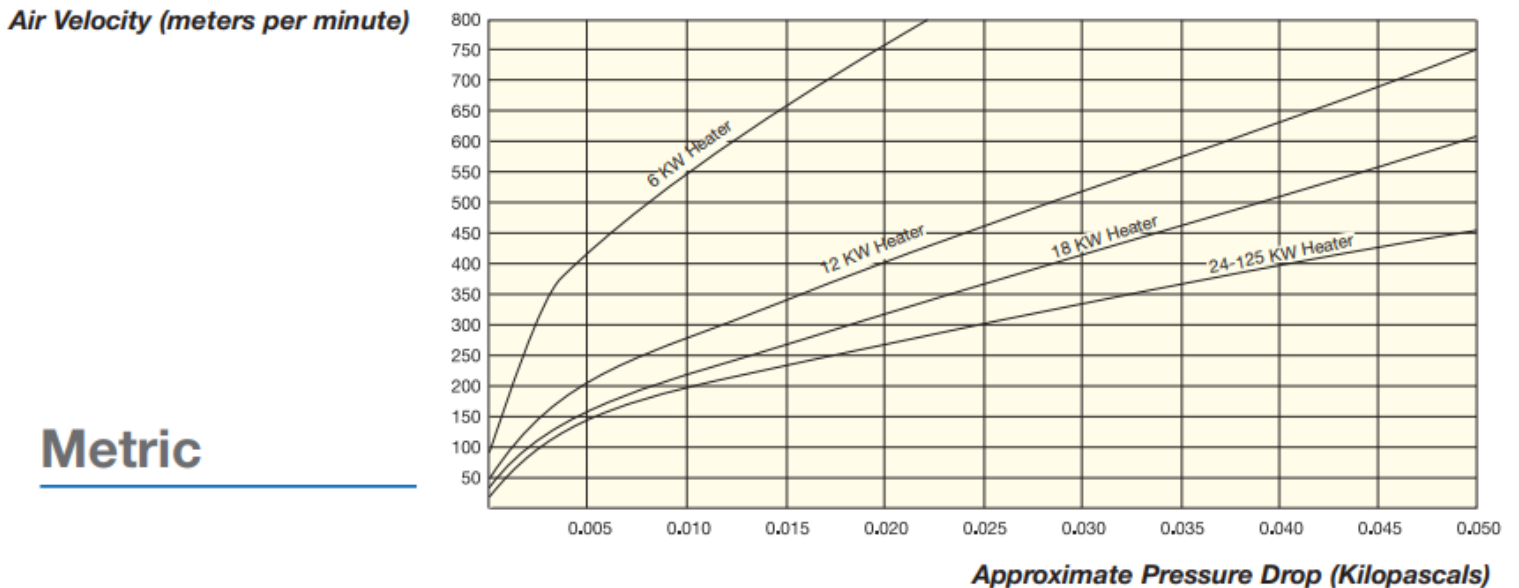

Fig 4. Pressure Drop vs. Air Velocity (For Sizing Blower)

Calculating Kilowatt Requirements

Once the volume of airflow (CFM - in cubic feet per minute) and the required temperature rise (ΔT - in degrees F) through the heater are known, the required kilowatt rating (KW) of the heater can be determined from the formula:

$$KW = \frac{CFM \times \Delta T^{\circ}F}{3193} \quad KW = \left(\frac{\text{Liters/Second} \times \Delta T^{\circ}C}{837} \right)$$

When the desired heating capacity in BTU/Hr is known, the KW is determined from the following formula:

$$KW = \frac{BTU/Hr}{3412}$$

Static Pressure Drop

Static pressure drop through an open coil or unfinned tubular elements is quite low and, in most cases, can be ignored when calculating system pressure drop.

In other hand, the pressure drop across a finned tubular heater is greater than across an open coil and unfinned tubular heater; but normally not enough to matter. It varies with flow velocity ranging from 0.04" H₂O at 500 fpm to about 0.30" H₂O at 1500 fpm when elements are banked together in several rows for duct heaters.

The curves in following figure 5 gives all the data in 3 constructions.

Minimum Air Velocity Required

Electric heaters differ from steam or hot water coils in that the heat output is constant as long as the heater is energized. Therefore, sufficient airflow must be provided to prevent overheating and nuisance tripping of the thermal cutouts.

The minimum required velocity is determined from Figure 6 on the basis of entering air temperature and KW per square foot of cross sectional duct area. The maximum air inlet temperature for open coil heaters is 100°F (38°C) and for finned tubular heaters is 80°F (27°C).

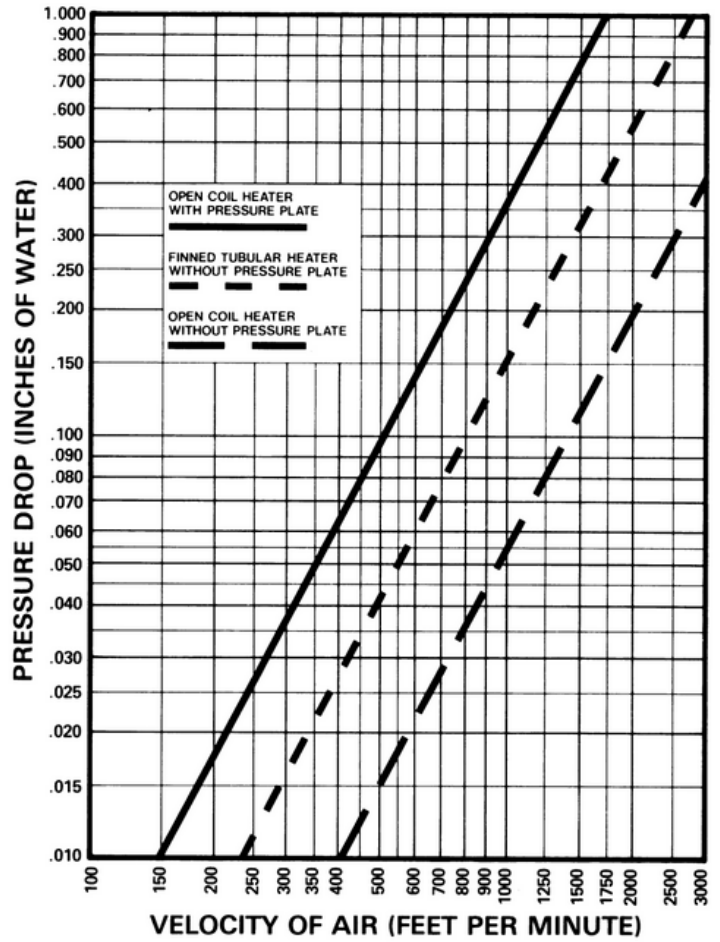

Fig 5. Types of Heaters' Pressure Drop vs. Air Velocity

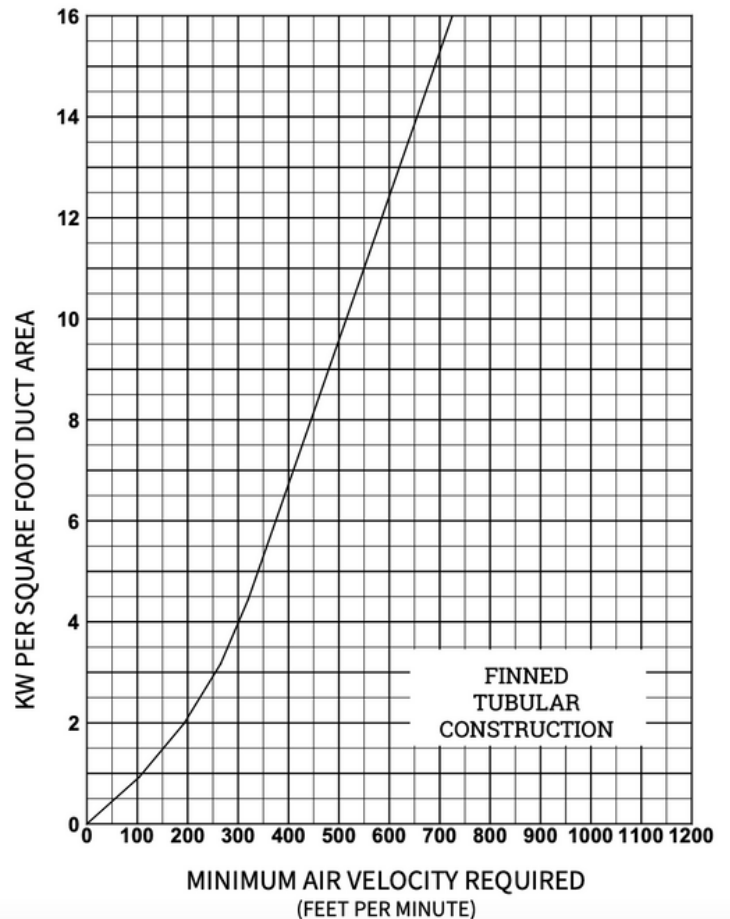

Fig 6. Minimum FPM for Finned Elements

Alternative Auxiliary Duct Heater Controls

- Duct Thermostats
 - Fixed Temperature Auto Reset Type
 - Fixed Temperature Manual Reset Type
 - Multi Temperature Range Adjustable Type
- Controller
- SCR Controllers
- Fixed Pressure Differential Switch
- Main Disconnect
- On/Off Switch
- Magnetic Contactors
- Step Controllers
- Load Fuses
- Control Transformers
- Secondary Manual Reset Thermal Cut-Out
- Pilot Lights

Installation Recommendations

- Duct heaters may be bolted to the ductwork through the side, bottom or top. Bottom and side mounting are preferred to minimize wiring/terminal enclosure temperatures.
- Before mounting, consideration should be given to the strength of the ductwork required to support the weight of the heater. Add additional hangers or supports as required.
- The inlet side of the unit should be at least 48 inches downstream from any change in duct size or duct direction.
- To minimize pressure drop, mount the duct with the narrow width of the heater perpendicular to the air flow.
- Duct heaters may be mounted in tandem to increase kW that can be installed.
- Process temperature sensing should be located downstream from the duct heater.
- Air flows must never be interrupted. Such events will cause overheating and/or premature heater burnout. Your installation should include high limit temperature controls. All standard duct heaters have a thermowell attached to one element for installing a thermocouple to sense element temperature. Additional protection for the heater from low air flow can be achieved by installing an air flow switch or pressure switch on the inlet side.
- Select the terminal housing that provides the best terminal protection from the environment surrounding the application.

Wiring Recommendations

- Power supply cables must have a minimum ampacity of 125% of the maximum heater load and be rated for the ambient temperature of the heater enclosure.
- The air handler should run on a time delay after the heater is de-energized. This allows the elements to cool down without over-heating adjacent areas.
- Duct heaters drawing more than 48 Amps are divided into smaller branch circuits, each drawing 48 Amps or less. Please note that the number of circuits, can be changed to accommodate any wiring requirements you may have.



Fig 7. 80kW Flanged Type Tubular Duct Heater

Maintenance Recommendations

- Never perform any type of service on duct heaters prior to disconnecting all power supply lines
- Periodically check the mounting screws and bolts have not become loose from blower vibration
- Periodically check that electrical connections are clean and tight

Typical Installation

- Tubular Duct Heaters

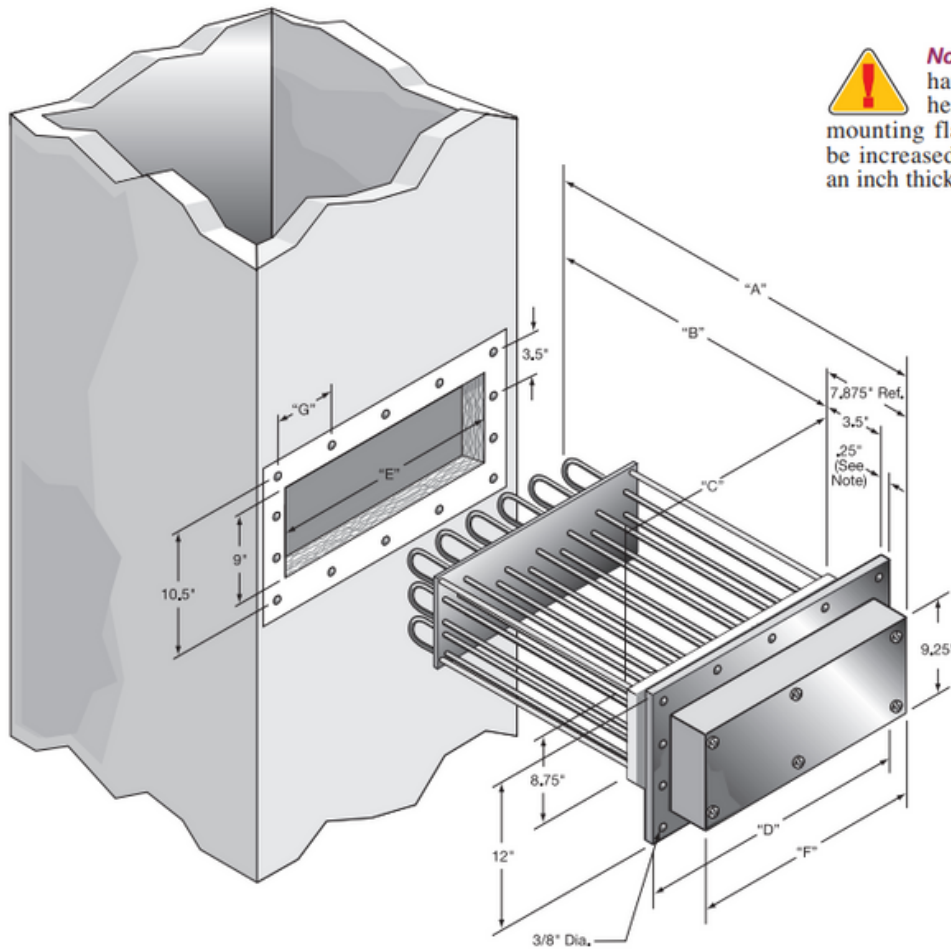

Standard (Non-Stock) Duct Heater Construction Specifications

Dimensions Reference Number	"A"		"B"		"C"		"D"		"E"		"F"		"G"		Number of Elements	Approximate Net Weight	
	in	mm	in	mm	in	mm	in	mm	in	mm	in	mm	in	mm		lbs	kgs
1	27 ⁷ / ₈	708	20	508	2 ¹ / ₄	70	6 ¹ / ₂	165	3	76	3 ³ / ₈	92	2 ¹ / ₂	64	6	22	10
2	27 ⁷ / ₈	708	20	508	4 ¹ / ₄	121	8 ¹ / ₂	216	5	127	5 ⁵ / ₈	143	3 ¹ / ₂	89	12	31	14
3	27 ⁷ / ₈	708	20	508	6 ¹ / ₄	171	10 ¹ / ₂	267	7	178	7 ⁷ / ₈	194	3	76	18	41	19
4	27 ⁷ / ₈	708	20	508	8 ¹ / ₄	222	12 ¹ / ₂	318	9	229	9 ¹ / ₄	244	2 ³ / ₄	70	24	51	23
5	27 ⁷ / ₈	708	20	508	10 ³ / ₄	273	14 ¹ / ₂	368	11	279	11 ³ / ₈	295	3 ¹ / ₄	83	30	62	28
6	27 ⁷ / ₈	708	20	508	12 ¹ / ₄	324	16 ¹ / ₂	419	13	330	13 ³ / ₈	346	3 ³ / ₄	95	36	73	33
7	27 ⁷ / ₈	708	20	508	14 ¹ / ₄	375	18 ¹ / ₂	470	15	381	15 ⁵ / ₈	397	4 ¹ / ₄	108	42	84	38
8	27 ⁷ / ₈	708	20	508	16 ¹ / ₄	425	20 ¹ / ₂	521	17	432	17 ³ / ₈	448	4 ³ / ₄	121	48	95	43
9	27 ⁷ / ₈	708	20	508	18 ³ / ₄	476	22 ¹ / ₂	572	19	483	19 ⁵ / ₈	498	5 ¹ / ₄	133	54	106	48
10	27 ⁷ / ₈	708	20	508	20 ³ / ₄	527	24 ¹ / ₂	622	21	533	21 ³ / ₈	549	5 ³ / ₄	146	60	117	53
11	32 ⁷ / ₈	835	25	635	20 ³ / ₄	527	24 ¹ / ₂	622	21	533	21 ³ / ₈	549	5 ³ / ₄	146	60	130	59
12	40 ⁷ / ₈	1026	32 ¹ / ₂	826	20 ³ / ₄	527	24 ¹ / ₂	622	21	533	21 ³ / ₈	549	5 ³ / ₄	146	60	155	70
13	49 ⁷ / ₈	1254	41 ¹ / ₂	1054	20 ³ / ₄	527	24 ¹ / ₂	622	21	533	21 ³ / ₈	549	5 ³ / ₄	146	60	180	82

Typical Installation

- Finned Duct Heaters

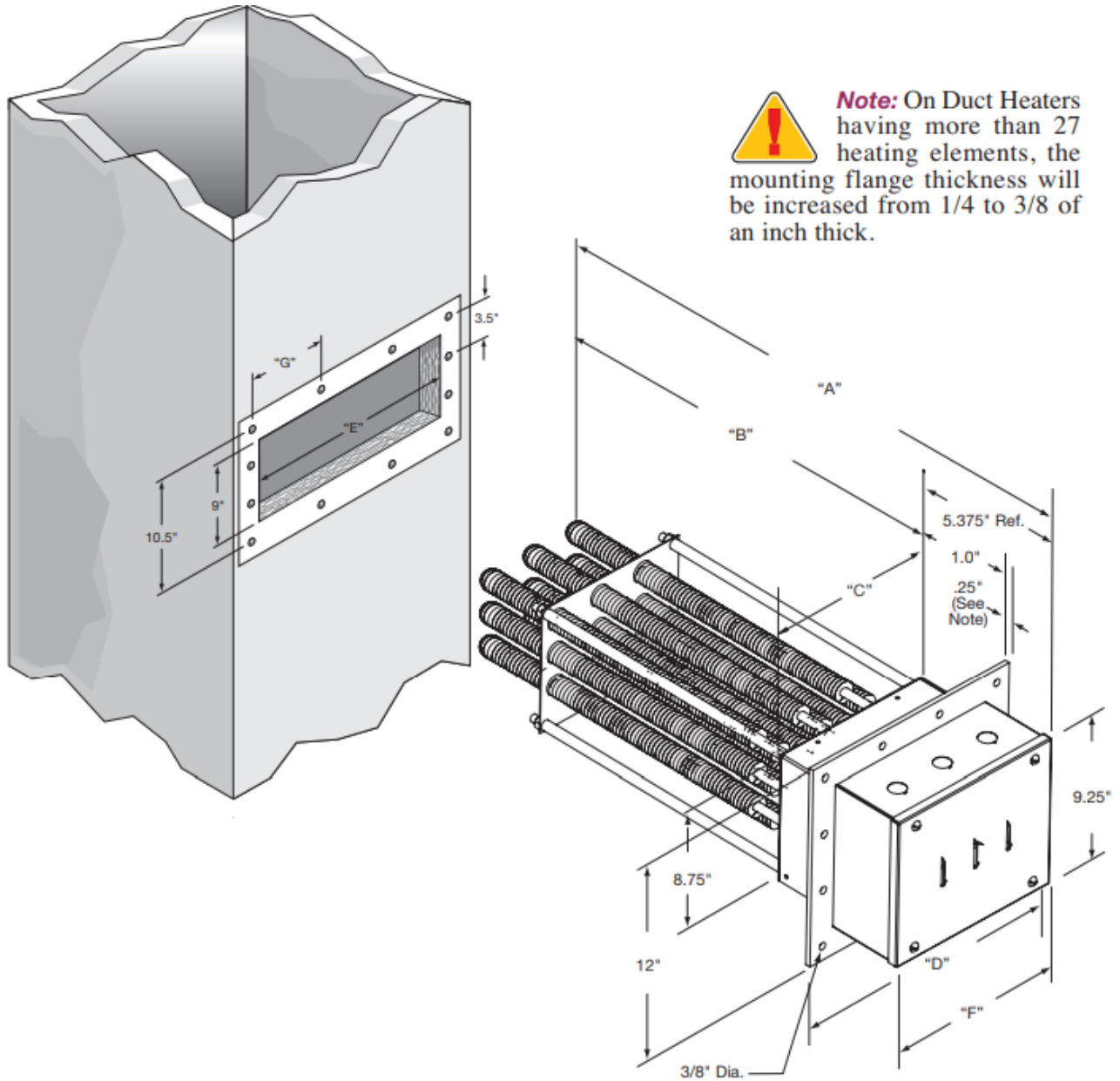

Standard (Non-Stock) Duct Heater Construction Specifications

Dimensions Reference Number	"A"		"B"		"C"		"D"		"E"		"F"		"G"		Number of Elements	Approximate Net Weight	
	in	mm	in	mm	in	mm	in	mm	in	mm	in	mm	in	mm		lbs	kgs
1	25 ³ / ₈	645	20	508	3 ¹ / ₄	95	7	177.8	4	102	4 ¹ / ₄	108	2 ³ / ₄	70	3	22	10
2	25 ³ / ₈	645	20	508	6 ¹ / ₄	159	9 ¹ / ₂	241	6.5	165	6 ¹ / ₄	171	4	102	6	31	14
3	25 ³ / ₈	645	20	508	8 ³ / ₄	222	12	305	9	229	9 ¹ / ₄	235	3 ¹ / ₂	89	9	41	19
4	25 ³ / ₈	645	20	508	11 ¹ / ₄	298	14 ¹ / ₂	368	12	305	11 ¹ / ₄	298	3 ³ / ₄	83	12	51	23
5	25 ³ / ₈	645	20	508	13 ³ / ₄	349	17	432	14	356	14 ¹ / ₄	362	3 ⁷ / ₈	98	15	62	28
6	25 ³ / ₈	645	20	508	16 ¹ / ₄	413	19 ¹ / ₂	495	16.5	419	16 ¹ / ₄	425	4 ¹ / ₂	114	18	73	33
7	25 ³ / ₈	645	20	508	18 ³ / ₄	476	22	559	19	483	19 ¹ / ₄	489	4 ³ / ₈	105	21	84	38
8	25 ³ / ₈	645	20	508	21 ¹ / ₄	552	24 ³ / ₄	622	22	559	21 ³ / ₄	552	4 ³ / ₈	117	24	95	43
9	25 ³ / ₈	645	20	508	23 ³ / ₄	603	27	686	24	610	24 ¹ / ₄	616	5 ³ / ₈	130	27	106	48
10	25 ³ / ₈	645	20	508	26 ¹ / ₄	679	29 ¹ / ₂	749	27	686	26 ³ / ₄	679	5 ⁷ / ₈	143	30	117	53
11	30 ¹ / ₄	768	24 ³ / ₄	632	26 ¹ / ₄	679	29 ¹ / ₂	749	27	686	26 ¹ / ₄	679	5 ³ / ₈	143	30	130	59
12	37 ¹ / ₄	946	31 ³ / ₈	810	26 ¹ / ₄	679	29 ¹ / ₂	749	27	686	26 ¹ / ₄	679	5 ³ / ₈	143	30	155	70
13	45	1143	39 ³ / ₈	1006	26 ¹ / ₄	679	29 ¹ / ₂	749	27	686	26 ¹ / ₄	679	5 ³ / ₈	143	30	180	82